

# OPERATING MANUAL

## BETA D-50 BATTERY TESTER / ANALYZER



# TABLE OF CONTENTS

<b>1. SYSTEM OVERVIEW .....</b>	<b>. 1</b>
<b>2. INSTALLATION .....</b>	<b>4</b>
<b>3. QUICK OPERATING GUIDE .....</b>	<b>6</b>
<b>4. DETAILED OPERATING INSTRUCTIONS ... ..</b>	<b>9</b>
<b>5. CALIBRATION AND MAINTENANCE ... ..</b>	<b>18</b>
<b>6. TROUBLE-SHOOTING .....</b>	<b>27</b>
<b>7. SPECIFICATIONS .....</b>	<b>29</b>
<b>APPENDIX A - BATTERY OVERVIEW ... ..</b>	<b>30</b>
<b>WARRANTY .....</b>	<b>32</b>
<b>CERTIFICATION OF CALIBRATION .....</b>	<b>33</b>

# 1. SYSTEM OVERVIEW

## 1.1 SYSTEM OVERVIEW

The Beta D-50 Tester/Analyzer is a self contained unit for discharge capacity testing of rechargeable batteries. It has been designed to accurately test and guarantee the emergency capacity of sealed or vented lead-acid or nickel-cadmium batteries. Guaranteed emergency capacity is especially important for aircraft batteries.

The Beta D-50 enables testing of a battery's capacity by loading it with a constant current of max 50 amperes (usually set to 80-100% of the battery's capacity rating) during a fixed period of time (usually 60 minutes). The D-50 analyzes the discharge characteristics and passes or fails the battery depending on the battery's ability to maintain a specified minimum voltage (cutoff voltage) for the duration of the test. The unit has pass/fail indicators as well as displays for discharge current, cutoff voltage, battery voltage, and test time.

The flexibility of test parameters of the Beta D-50 makes it usable for a wide variety of batteries and voltages. The unit accurately tests lead-acid batteries of 12 or 24 volts, as well as nickel-cadmium batteries up to 24 volts.

The use of solid state circuits in the Beta D-50 has kept its weight to a mere 30 lbs. (14 kg). Consequently the unit is easy to move around to accommodate flexibility in the work environment.

## 1.2 DISPLAYS AND CONTROLS

The Beta D-50 has been designed to have very simple and easy to understand controls and displays (see figure 1-1 and 1-2).



Figure 1-1. Front view of Beta D-50

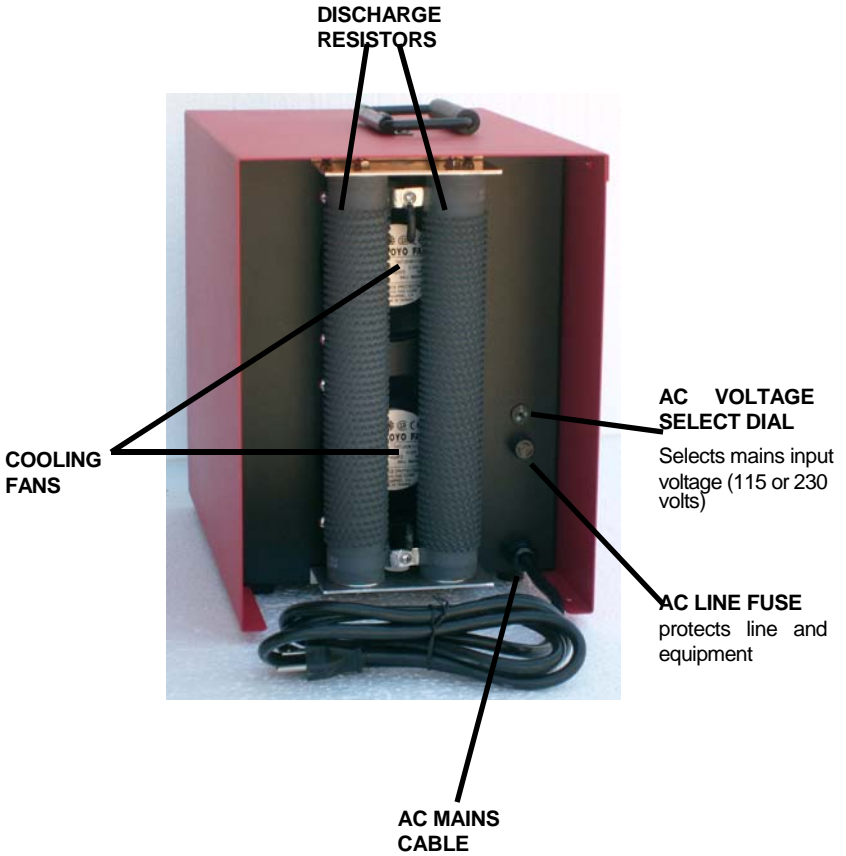

Figure 1-2. Rear view of Beta D-50

## 2. INSTALLATION

### 2.1 LINE VOLTAGE

The Beta D-50 can operate on either 115 or 230 Volts AC. The desired line voltage can be selected on the rear of the unit.

**CAUTION:** Ensure that the unit is set for the appropriate line voltage before operation.

- A. On the back of the unit locate the AC voltage select dial.
- B. Set dial for appropriately marked AC voltage (115 or 230 volts) using a screwdriver.
- C. For 230 VAC operation, the 115 VAC plug must be replaced with one for 230 VAC in required configuration.

**NOTE:** If the plug has to be changed make sure to connect the green AC line wire to ground.

Connect the unit to a wall outlet with at least a 10 ampere capacity. Sharing of the line with other equipment may result in erratic operation if other equipment draws high pulse or surge currents.

**NOTE:** The Beta D-50 will maintain its operational integrity with line fluctuation less than  $\pm 10\%$ .

### 2.2 TERMINALS

Two important points about the DC battery cable and connector are:

- A. If the aircraft battery quick disconnect connector is removed, the ring terminals can be used to connect to a post terminal battery.

**WARNING :** Correct polarity must be observed.

- B. If the cable is extended or repaired during maintenance, the sensing leads which run with the heavy DC cable must be connected to the new terminal (see section 5.5).

## 2.3 SPACE REQUIREMENTS

The Beta D-50 system occupies 15" x 10 ¼" (381 mm x 260 mm) of table top space. Place the unit on a sturdy workbench in a well-ventilated battery servicing area with the battery adjacent to it.

The rear of the unit has air flow from hot resistors. Allow at least 6" (150 mm) of separation from the wall and adjacent equipment in order to maintain proper air flow.

**WARNING:** Due to the air flow from hot resistors on the rear of the unit, use extreme caution on placement.

**NOTE:** In non air-conditioned rooms it is recommended that circulating or extracting fans be used to aid in the removal of heated air.

**NOTE:** Operation in dusty or otherwise dirty air environments will severely reduce the cooling capacity of the fans and can lead to premature failure.

## 3. QUICK OPERATING GUIDE

This section gives an overview of how to quickly get started capacity discharge testing a battery using your Beta D-50. If there is uncertainty at any point on how to proceed, please refer to the more detailed instructions in the section 4.

**WARNING:** Always turn the AC power switch off before connecting or disconnecting a battery

**NOTE:** Once set, all settings are maintained and need not be reset for duplicate testing

### A. SWITCH OFF MAINS POWER

Turn off the AC on-off/reset power switch.

### B. TURN DOWN DISCHARGE CURRENT

Turn the Ampere Adjust knob fully counter-clockwise to set discharge current to zero.

### C. CONNECT BATTERY

Connect the battery DC cable to the battery and ensure the connector is plugged in completely.

### D. SWITCH ON MAINS POWER

Turn on the AC on-off/reset power switch. An audible alarm sounds, and the Accept lamp illuminates. Meters read all 6's or 8's.

### E. SET TIMER

Set the timer by pushing buttons up or down to the required discharge time (usually 60 minutes)



## F. VIEW AND SET CUTOFF VOLTAGE

a. Press and hold the View Voltage Cutoff button. The set cutoff voltage is shown on the voltmeter display.

NOTE: If the meters continue to read all 6's or 8's, the cutoff voltage is set higher than battery voltage and must be lowered. Adjust the cutoff voltage pot until the meters change (it may take multiple turns of the 15 turn pot)

b. Use the supplied tool or a 1/16 inch (2 mm) slot blade precision type screw driver to adjust the cutoff voltage to the desired level.

## G. PUSH START BUTTON

The audible alarm stops. The voltmeter displays the battery voltage, the ammeter reads 0 and the timer starts. The red LED on the timer illuminates. "OP" on the timer illuminates and the red LED flashes.

## H. SET DISCHARGE CURRENT

Slowly turn the multi-turn Ampere Adjust knob clockwise to the desired discharge current. The ammeter displays the current as it is being adjusted.

## I. WAIT FOR THE DISCHARGE TEST TO AUTOMATICALLY COMPLETE

During the test the battery voltage, discharge current, and elapsed discharge time are displayed. The voltage will continuously decrease while the current remains constant. The test completes when either the set discharge time or the low cutoff voltage has been reached. An audible alarm sounds and the displays freeze at their final values.

## J. 1. IF TEST PASSED

The green Accept lamp illuminates. This indicates the discharge has continued through the duration of the set discharge time (the red LED and "OP" on timer is off.) without the cutoff voltage being reached. The battery is usually fit for service, after complete recharge. See below under respective battery type.

## 2. IF TEST FAILED

The Fail lamp illuminates if the discharge has been discontinued because the cutoff voltage has been reached before the completion of the set discharge time. The red LED goes out. The time is frozen at the elapsed time at which the test failed. The battery is in need of reconditioning or must be rejected for aircraft service. Refer to the battery manufacturer's maintenance manual on how to proceed.

## K. SWITCH AC POWER OFF

Switch the AC on-off/reset switch off before removing the battery.

**NOTE:** If in emergency it is required to stop the test, switch the unit to off/reset. When the test is restarted the timer is reset to zero. It may be necessary to recharge the battery before resuming the test.

## 4. DETAILED OPERATING INSTRUCTIONS

### 4.1 DISCHARGE CHARACTERISTICS

The lead-acid and the nickel-cadmium cells are generally assigned nominal open circuit voltages of 2.10 volts and 1.35 volts respectively. Actual open circuit voltage at 75°F/ 25°C for a fully charged battery cell depends on state-of-charge and time after charge.

During discharge, the voltage of the cell or battery immediately begins to decrease because of the effective internal resistance of the cell. This includes the resistance of the terminal posts, active material, plate lugs and grids, separators, and contact resistance between the surface of the active material and the electrolyte. The internal resistance increases during discharge, being greater toward the end of discharge, when the terminal voltage is lower.

As voltage gradually becomes lower during discharge, the point of near exhaustion is reached. At this point, the discharge voltage curve begins to drop very sharply to a value which is of no further practical use. Usually this happens at 18-20 volts for a 24 volt lead-acid battery and 1 volt per cell for a nickel-cadmium battery (see figure 4-1).

Battery manufacturers specify a cutoff voltage which the battery must exceed during a discharge test to have acceptable capacity. The cutoff voltage varies with the rate of discharge (the discharge current/time combination used to draw the same capacity). For example, the minimum cutoff voltages for a 30 ampere-hour, 24-volt naval aircraft lead-acid storage battery are generally specified as is shown in table 4-1.

Rate of Discharge	Discharge Current	Minimum Cutoff Voltage
5 hours	6 amperes	21.0 volts
2 hours	15 amperes	19.2 volts
1 hour	30 amperes	18.0 volts

**Table 4-1. Cutoff voltages at different discharge rates for a 30 ampere-hour, 24 volt lead-acid battery**

The specified final minimum cutoff voltage represents the value of voltage at which the rated ampere-hour capacity of the battery must have been delivered for the specified discharge rate. Figure 4-1 is a typical discharge curve for a 40 ampere-hour sealed lead-acid (SLAB) aircraft storage battery discharged at a 1-hour rate of 40 amperes. From figure 4-1, it is observed that at the end of 1 hour of discharge time, the battery voltage has reduced only to about 22 volts. Because the minimum required cutoff voltage is 18 volts at the 1-hour discharge rate, the battery exceeds the minimum requirements. With increasing hours of use or age, the battery capacity decreases. Therefore, battery manufacturers usually recommend testing for a capacity equal to 80% of the original ampere-hour rating.

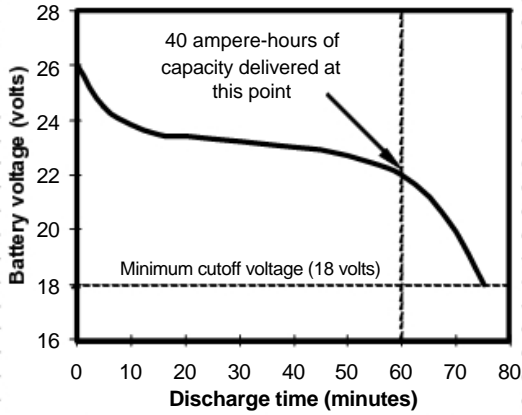

**Figure 4-1. Typical discharge curve for 40 ampere-hour lead-acid aircraft battery**

Figure 4-2 illustrates discharge curves for typical SLABs at different discharge rates. Note that the cell voltage drops much more rapidly at the higher discharge rates, i.e. the rates at which a greater current is drawn during a shorter period of time.

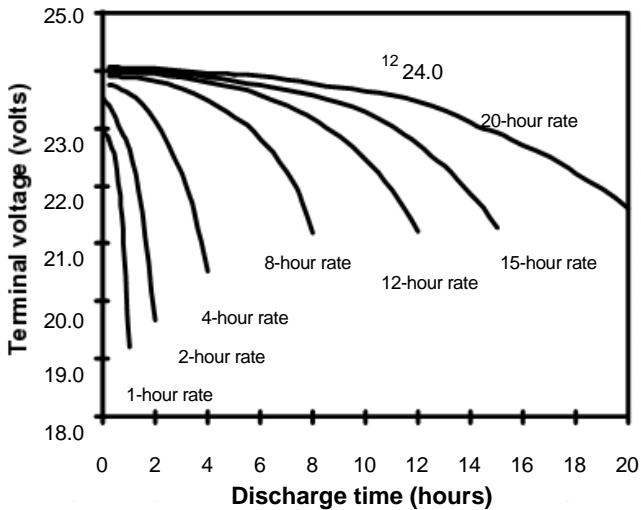

**Figure 4-2. Typical discharge curves for SLABs at different rates**

The discharge of a lead-acid battery beyond the point of which exhaustion of the cell is approached can be harmful, as the battery may form a sulfate deposit on its plates. This is particularly true if the battery is not soon recharged.

## 4.2 DISCHARGE CAPACITY TESTING

The purpose of a discharge test is to determine the long-term capacity of the battery. For a lead-acid aircraft battery, for example, the capacity test is the amount of current which can be delivered for one hour or until the voltage decreases to 1.5 volts per cell. This is considered the emergency capacity of the battery. The result of the test will determine whether to accept or reject the battery and which steps could be taken to electrically recondition the battery.

The amount of electrical capacity available from a fully charged nickel-cadmium or lead acid battery is defined by the capacity rating of the battery and is stated in terms of ampere hours. Because of internal resistance, the higher the discharge rate (higher current during a shorter period of time) demanded of a battery, the less usable capacity it can supply. See figure 4-2.

### 4.2.1 Constant-Current Discharge Method

The most accurate and repeatable method of measuring capacity is to discharge the battery at a constant-current rate. This is also the method used by the Beta D-50. The load resistance in this method is continuously and automatically varied to maintain a constant discharge current as the battery's voltage decreases. A schematic of the circuit diagram for the Beta D-50 can be seen in figure 4-3. At the end of discharge, the calculation of ampere-hour capacity is the product of discharge current and the elapsed discharge time.

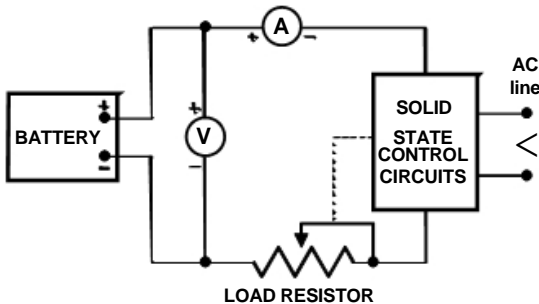

Figure 4-3. Circuit diagram for constant current discharge test

**NOTE:** Always read the battery manufacturer's operating instructions. Some lead-acid batteries are recommended at a 20 volt cutoff when tested for an hour at 80% of rated capacity. Some nickel-cadmium battery requirements are testing for two hours at half the rated capacity, and a 1 volt per cell cutoff.

## 4.3 PREPARATION FOR TESTING

Before starting the discharge test, read the component maintenance manual (CMM) or the operating and maintenance manual (OMM) for the specific battery to be tested. Ensure that the discharge rate and cutoff voltage from the battery manufacturer are followed.

It is recommended that a visual inspection of the battery is carried out in conjunction with testing and charging batteries.

The battery must be fully charged before testing starts, except for special tests.

**WARNING:** Always turn off the AC power switch before connecting or disconnecting a battery.

**NOTE:** The test, unless otherwise specified in the manufacturer's CMM/OMM, shall be conducted at room ambient temperature of 70°F to 85°F (21°C to 29°C).

### A. SWITCH OFF MAINS POWER

Turn off AC on-off/reset power switch.

### B. TURN DOWN DISCHARGE CURRENT

Repeatedly turn the Ampere Adjust knob fully counter-clockwise to set discharge current to zero. This prevents excess current, which may be too high for the battery, once the battery is connected and the discharge test has begun.

## 4.4 DISCHARGE TIME

### 4.4.1 TIMER UNIT SETTING

The Beta D-50 has a built in timer, allowing discharge time settings from 0 minutes to 999.9 minutes.

#### 4.4.2 DISCHARGE TIME SETTING

The discharge time is usually set to 60 minutes, after which a pass/fail signal is given based on whether the battery reached the cutoff voltage or not.

To determine the full capacity of the battery a longer time can be set (several hours). The Beta D-50 will then continue the discharge test only until the cutoff voltage has been reached. The timer, cutoff voltage and discharge current displays will freeze at this point. The capacity can be calculated as the product of the discharge current and the time passed until the voltage cutoff was reached.

### C. SET TIMER

Set the timer by pushing buttons up or down to the required discharge time (usually 60 minutes)

**CAUTION.** For lead-acid batteries the time and voltage cutoff should be set with caution. If discharge continues too far beyond the point of exhaustion it may be harmful to the battery, unless the battery is soon to be recharged.

### 4.5 CUTOFF VOLTAGE

The Beta D-50 will automatically stop the discharge test when the cutoff voltage has been reached. The cutoff voltage is set so that if the battery voltage is higher than the cutoff voltage when the discharge time has expired, the battery has passed the capacity test.

#### 4.5.1 LEAD-ACID BATTERIES

Always refer to your battery manufacturer's maintenance manual for the most accurate information. For a 24 volt sealed lead-acid battery the cutoff voltage is usually set at 18 or 20 volts when discharged one hour at a current equal to the 80% of the battery's  $C_1$ -rate. See table 4-2 for examples of discharge test settings for sealed lead-acid batteries.

1-hour rating		Discharge settings		
Volts	Ampere hours	Time (min)	Rate (amperes)	Cutoff (volts)
24	10	60	8	18/20
24	15	60	12	18/20
24	20	60	16	18/20
24	30	60	24	18/20
24	40	60	32	18/20
12	10	60	8	9/10
12	15	60	12	9/10
12	20	60	16	9/10
12	30	60	24	9/10
12	40	60	32	9/10

**Table 4-2. Discharge test setting for sealed lead-acid batteries**

#### 4.5.2 NICKEL-CADMIUM BATTERIES

For nickel-cadmium batteries the cutoff voltage should equate to an average of 1 volt per cell, when discharge tested at a current of approximately 80% of the  $C_1$ -rate. For a 24 volt/10 ampere-hour battery with 19 cells, the cutoff voltage would be set to 19 volts when discharging at 8 amperes (see table 4-3).

1-hour rating		Discharge settings		
Volts	Ampere hours	Time (min)	Rate (amperes)	Cutoff (volts)
24	10	60	8	19
24	15	60	12	19
24	20	60	16	19
24	30	60	24	19
24	40	60	32	19
12	10	60	8	10
12	15	60	12	10
12	20	60	16	10
12	30	60	24	10
12	40	60	32	10

**Table 4-3. Discharge test setting for nickel-cadmium batteries**

#### 4.5.3 SETTING CUTOFF VOLTAGE ON THE BETA D-50

Before setting the cutoff voltage, a battery has to be connected and the unit has to be turned on.



## D. CONNECT BATTERY

Connect the battery DC cable to the battery and ensure the connector is plugged in completely.

## E. SWITCH ON MAINS POWER

Turn on the AC on-off/reset power switch. An audible alarm sounds, and the Accept lamp illuminates. Meters read all 6's or 8's.

## F. VIEW AND SET CUTOFF VOLTAGE

a. Press and hold the View Voltage Cutoff button. The set cutoff voltage is shown on the voltmeter display.

**NOTE:** If the meters continue to read all 6's or 8's, the cutoff voltage is set higher than battery voltage and must be lowered. Adjust the cutoff voltage pot until the meters change (it may take multiple turns of the 15 turn pot)

b. Use the supplied tool or a 1/16 inch (2 mm) slot blade precision type screw driver to adjust the cutoff voltage to the desired level.

**NOTE:** Actual cutoff voltages are slightly lower than the set nominal voltage in order to give the battery an "accept advantage" and allowing the operator to observe a marginal battery and decide its acceptance or rejection. The actual cutoff value also depends on how fast the battery voltage is changing. Of course, the higher the voltage at acceptance, the better the battery.

## 4.6 SETTING DISCHARGE CURRENT

The discharge current in amperes is normally set equal to, or 80% of, the battery nominal 1-hour capacity rating (please refer to the battery manufacturer's maintenance manual). For example, a SLAB battery with a 30 ampere-hour 1-hour capacity rating would be tested with the discharge current set to 24 amperes.

Before setting the discharge current the Beta D-50 must have been connected to the battery (see section 4.5) and the AC power switch must have been turned on.

## **G. PUSH START BUTTON**

The audible alarm stops. The voltmeter displays the battery voltage, the ammeter reads 0 and the timer starts. "OP" on the timer illuminates and the red LED flashes.

## **H. SET DISCHARGE CURRENT**

Slowly turn the multi-turn Ampere Adjust knob clockwise to the desired discharge current. The ammeter displays the current as it is being adjusted.

### **4.7 TEST COMPLETION AND ANALYSIS**

The Beta D-50 automatically completes the test with the set parameters. It may however be required to measure the individual cell voltages for nickel-cadmium batteries during the test (see section 4.7.2).

## **I. WAIT FOR THE DISCHARGE TEST TO AUTOMATICALLY COMPLETE**

During the test the battery voltage, discharge current, and elapsed discharge times are displayed. The voltage will continuously decrease while the current remains constant. The test completes when either the set discharge time or the low cutoff voltage has been reached. An audible alarm sounds and the displays freeze at their final values.

## **J. 1. IF TEST PASSED**

The green Accept lamp illuminates. This indicates the discharge has continued through the duration of the set discharge time (the red LED and "OP" on timer is off) without the cutoff voltage being reached. The battery is usually fit for service, after complete recharge. See 4.7.1 and 4.7.2 for respective battery type.

## 2. IF TEST FAILED

The Fail lamp illuminates if the discharge has been discontinued because the cutoff voltage has been reached before the completion of the set discharge time. The red LED goes out, but the time is frozen at the elapsed time at which the test failed. The battery is in need of reconditioning or must be rejected for aircraft service. Refer to the battery manufacturer's maintenance manual on how to proceed.

### 4.7.1 LEAD-ACID BATTERY

If the lead-acid battery has been accepted by the Beta D-50 discharge test it has successfully completed the capacity test.

### 4.7.2 NICKEL-CADMIUM BATTERY

Check each cell with a digital voltmeter near the end of the test.

- A. If no cells have dropped below 1.0 volts at the end of the specified time the battery has successfully completed the capacity test.
- B. If any cells have dropped below 1.0 volt before or at the end of the capacity test the battery must be reconditioned (deep cycled). Please refer to the battery manufacturer's maintenance manual on how to proceed.

## K. SWITCH AC POWER OFF.

Switch the AC on-off/reset switch off before removing the battery

**NOTE:** If in emergency it is required to stop the test, switch the unit to off/reset. When the test is restarted the timer is reset to zero. It may be necessary to recharge the battery before resuming the test.

## 5. CALIBRATION AND MAINTENANCE

### 5.1 OVERVIEW OF CALIBRATION

The Beta D-50 has been calibrated before shipment from the manufacturer. A certificate of calibration has been issued and is enclosed in the back of this manual. To ensure error-free operation over time the unit should be re-calibrated every 12 months depending on usage and changes in surrounding environment.

#### 5.1.1 DIGITAL PANEL METERS

There are two main indicators that can be periodically calibrated: 1) the voltmeter; and 2) the ammeter (see figure 1-1 in section 1). The Beta D-50 is equipped with two sets of test jacks for easy calibration of these digital display meters. In addition the internal shunt, even though calibrated and certified by the shunt manufacturer, could be verified.

#### 5.1.2 TIMER

The timer is a very accurate crystal-controlled device, not prone to error. It cannot be recalibrated, but unless an extremely accurate time reading is required, an accurate analog or digital stop watch is adequate to validate its accuracy.

#### 5.1.3 OPERATING RANGE

The Beta D-50 discharge current operating range can be modified if either 1) the lower limit is off zero; or 2) a maximum limit different than factory-preset 50 amperes discharge current is desired.

**WARNING:** Calibration should only be performed by trained personnel. If performed incorrectly it could result in electrical shock leading to injury or death.

### 5.2 VOLTMETER CALIBRATION

To calibrate the Beta D-50 voltmeter, an external calibrated digital voltmeter is required as well as a fully charged battery. The circuit diagram for the calibration can be seen in figure 5-1. The calibration steps are outlined below.

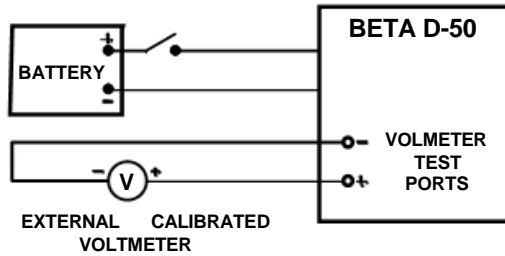

Figure 5-1 - Circuit diagram for voltmeter calibration

## A. SWITCH OFF MAINS POWER

Turn off the AC on-off/reset power switch.

## B. TURN DOWN DISCHARGE CURRENT

Repeatedly turn the Current Adjust knob fully counter-clockwise to set discharge current to zero.

## C. CONNECT BATTERY

Connect the battery DC cable to the fully charged battery and ensure the connector is plugged in completely.

## D. PLUG IN VOLTMETER

Plug in the external digital voltmeter into the voltmeter calibration ports. Set it to a DC voltage range appropriate for the connected battery.

## E. SWITCH ON MAINS POWER

Turn on the AC on-off/reset power switch. An audible alarm sounds, and the Accept lamp illuminates. Meters read all 6's or 8's.

## **F. SET TIMER**

Set the timer by pushing the buttons up or down to a time that will allow calibration to be completed before the time runs out (for example 60 minutes).

## **G. VIEW AND SET CUTOFF VOLTAGE**

- a. Press and hold the View Voltage Cutoff button. The set cutoff voltage is shown on the voltmeter display.
- b. Use a 1/16 inch (2 mm) slot blade precision type screw driver to adjust the cutoff voltage. Set it to a value that will allow calibration to be completed before the cutoff voltage is reached. For example 18 volts for a 24 volt battery or 9 volts for a 12 volt battery.

## **H. PUSH START BUTTON**

The audible alarm stops. The voltmeter displays the battery voltage, the ammeter reads 0 and the timer starts. "OP" on the timer illuminates and the red LED flashes.

## **I. COMPARE VOLT READINGS**

Compare the Beta D-50 digital voltmeter reading with the external calibrated voltmeter.

- a. If readings differ less than  $\pm 0.2$  volts, the voltmeter is accurately calibrated. Turn AC power off and disconnect battery.
- b. If readings differ more than  $\pm 0.2$  volts, continue with steps J through L.

## J. REMOVE THE COVER

If voltmeter differs more than  $\pm 0.2$  volts, remove the unit's L-shaped cover by unscrewing the four screws

- a. Two on top left side of unit
- b. Two on bottom right side of unit

**WARNING:** Calibration needs to be performed with the unit's cover removed as well as both mains power and battery connected. It should only be performed by trained personnel. If performed incorrectly it could result in electrical shock leading to injury or death.

## K. CALIBRATE VOLTMETER

The voltmeter can be found on the back side of the front panel. Locate the voltmeter trimpot.

Using a 1/16 inch (2 mm) slot blade precision type screw driver, adjust the embedded trimpot located at the rear of the voltmeter. Adjust until voltmeter reading matches that of the calibrated voltmeter (at least within  $\pm 0.2$  volts).

## L. REPEAT FOR ADDITIONAL VOLTAGES

To verify the accuracy over the range of the meter, additional voltages could be checked. Since the Beta D-50 digital meters are linear, checking two or three voltages are adequate to verify the range. The easiest way to check an additional voltage is to repeat step I but to turn up the discharge current to 1/3 of the rated ampere-hours (i.e. 13 amperes for a 40 ampere-hour battery).

## 5.3 AMMETER CALIBRATION

To calibrate the Beta D-50 ammeter, an external calibrated digital voltmeter, set to the millivolt range, is required as well as a fully charged battery. The millivoltmeter will read the millivolts dropped across the Beta D-50 internal shunt when a discharge current is drawn. The circuit diagram for the calibration can be seen in figure 5-2. The calibration steps are outlined below.

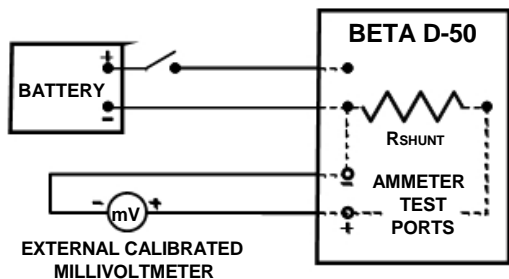

Figure 5-2 Circuit diagram for ammeter calibration

## A. SWITCH OFF MAINS POWER

Turn off the AC on-off/reset power switch.

## B. TURN DOWN DISCHARGE CURRENT

Repeatedly turn the Current Adjust knob fully counter-clockwise to set discharge current to zero.

## C. CONNECT BATTERY

Connect the battery DC cable to the battery and ensure the connector is plugged in completely.



## D. PLUG IN MILLIVOLTMETER

Plug in the external voltmeter into the ammeter calibration ports. Set it to a millivolts setting (most voltmeters have a 300 mV setting).

## E. SWITCH ON MAINS POWER

Turn on the AC on-off/reset power switch. An audible alarm sounds, and the Accept lamp illuminates. Meters read all 6's or 8's.

## F. SET TIMER

Set the timer by pushing buttons up or down to a time that will allow calibration to be completed before the time runs out (for example 60 minutes).

## G. VIEW AND SET CUTOFF VOLTAGE

- a. Press and hold the View Voltage Cutoff button. The set cutoff voltage is shown on the voltmeter display.
- b. Use a 1/16 inch (2 mm) slot blade precision type screw driver to adjust the cutoff voltage. Set it to a value that will allow calibration to be completed before the cutoff voltage is reached. For example 18 volts for a 24 volt battery or 9 volts for a 12 volt battery.

## H. PUSH START BUTTON

The audible alarm stops. The voltmeter displays the battery voltage, the ammeter reads 0 and the timer starts. "OP" on the timer illuminates and the red LED flashes.

## I. SET DISCHARGE CURRENT

Turn the Ampere Adjust knob clockwise to the rated ampere-hours, i.e. 40 amperes for 40 ampere-hour battery. The ammeter displays the current as it is being adjusted.

## J. COMPARE READINGS

Compare the Beta D-50 digital ammeter with the external millivoltmeter. The external meter reads the millivolt drop across a 50 ampere/50 millivolt shunt. Every millivolt read on the external millivoltmeter represents 1 ampere. The readings should be within  $\pm 0.2$  millivolts (amperes).

- a. If readings differ less than  $\pm 0.2$  millivolts, the ammeter is accurately calibrated. Turn AC power off and disconnect battery.
- b. If readings differ more than  $\pm 0.2$  millivolts, continue with steps K through M.

## K. REMOVE THE COVER

If voltmeter differs more than  $\pm 0.2$  amperes (millivolts), remove the unit's L-shaped cover by unscrewing the four screws

- a. Two on top left side of unit
- b. Two on bottom right side of unit

**WARNING:** Calibration needs to be performed with the unit's cover removed as well as both mains power and battery connected. It should only be performed by trained personnel. If performed incorrectly it could result in electrical shock leading to injury or death.

## L. CALIBRATE AMMETER

The ammeter can be found on the back side of the front panel. Locate the ammeter trimpot.

Using a 1/16 inch (2 mm) slot blade precision type screw driver, adjust the embedded trimpot located at the rear of the ammeter. Adjust until ammeter reading matches that of the calibrated millivoltmeter (at least within  $\pm 0.2$  amperes or millivolts).

## M. REPEAT FOR ADDITIONAL CURRENT SETTINGS

To verify the accuracy over the range of the meter, additional current settings could be checked. Since the Beta D-50 digital meters are linear, checking two or three current settings are adequate to verify the range. The easiest way to check additional current settings is to repeat steps I and J but setting a lower discharge current in step I.

## 5.4 SHUNT VERIFICATION

The Beta D-50 internal shunt is calibrated and certified by the shunt manufacturer. The shunt is a linear resistive device consisting of a heavy brass base and heavy manganin (copper alloy) resistance. It is not necessary to calibrate the shunt, however the shunt could be verified with the help of an external calibrated shunt and a millivoltmeter (see figure 5-3).

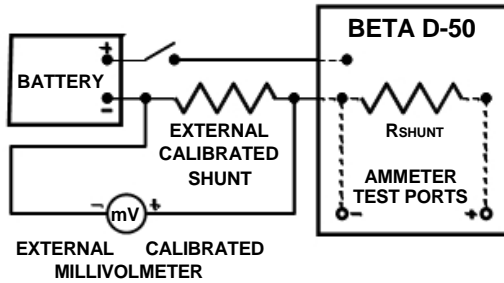

Figure 5-3 Circuit diagram for shunt verification

## 5.5 MAINTENANCE

Standard electrical equipment maintenance and cleaning procedures should be followed.

### 5.5.1 VENTS AND FAN

Regularly check that the rear fan vents are clean to ensure adequate cooling of the unit. This is especially important when the unit is placed in a dusty or otherwise dirty air environment.

### 5.5.2 DC BATTERY CABLE AND LEADS

Inspect DC battery cable and connector periodically. Replace damaged or worn cable.

**WARNING:** Disconnect AC voltage and battery before attempting to replace or secure cable

The DC cable contains 4 leads. Two are heavy-gauge DC current leads for the battery discharge current. Two are light-gauge leads for sensing the battery voltage. Each current carrying lead has its sensing lead attached at the battery quick disconnect.

To replace DC battery cable proceed as follows:

- 1) Disconnect AC line and battery
- 2) Remove unit cover
- 3) Replace old cable from connector and unit
- 4) Make sure that each sensing lead is securely soldered or crimped to the termination of the DC cable at the connector and at the internal termination
- 5) Check all leads for tightness

### 5.5.3 REPLACEMENT OF FUSES

The Beta D-50 is equipped with two fuses. One 3 ampere AC line fuse and one 70 ampere DC line fuse. See specification in section 7 for the specific types of fuses required.

**WARNING:** Disconnect AC voltage and battery before attempting to replace any fuses.

To replace the AC line fuse unscrew the fuse cover on the rear of the unit and exchange the old fuse (see picture).

To replace the DC line fuse remove the unit cover. Remove the old fuse located on either the base or the side of the unit. Replace with the new fuse.

### 5.5.4 CLEANING AGENTS

Do not use acetone and other similar cleaning agents on the meters, timer or any plastic part.

## 6. TROUBLE-SHOOTING

<b>Problem</b>	<b>Possible Cause</b>	<b>Corrective Action</b>
A. Unit will not turn on	The AC power is not connected to unit	Check AC line with voltmeter
	AC line fuse is blown. May be due to incorrect AC line voltage setting.	Ensure correct AC line voltage setting on back of unit. (see section 2.1)  Replace AC line fuse located on the lower right hand side on the rear of the unit (see section 5.6)
B. Unit turns on but will not start (timing)	Timer is set to zero time, or incorrectly to seconds or low decimal unit.	Increase the timer setting (see section 4.4)
C. Battery voltage reading erratic or not reading	Voltage sensing lead(s) at battery connector loose or broken	Replace or secure leads with both AC voltage and battery disconnected (see section 5.6)
D. Discharge test will not start	Battery is not sufficiently charged to start the test	Recharge battery before retrying discharge test
	Timer is set to zero time, or incorrectly to seconds or low decimal unit.	Increase the timer setting (see section 4.4)
	Cutoff voltage set higher than the actual battery voltage	Reset the cutoff voltage to a lower voltage (see section 4.6) or recharge battery.
	The lead-acid battery is sulfated and will not support a load	Recondition or reject the battery
E. Battery sufficiently charged but discharge test fails immediately as discharge current is increased	High resistance or open circuit in DC cable at Elcon connector, in the cable itself, or in the voltage sensing leads attached to connector	Inspect and measure resistance in DC cable and connector. If high or intermittent high resistance, the cable needs to be replaced
	The lead-acid battery is sulfated	Check all terminals. Set a low discharge current and look for arcing or heat generation.
	The nickel-cadmium battery inter-cell connectors are loose or contaminated causing high resistance	Check all terminals and inter-cell connectors. Set a low discharge current and look for arcing or heat generation.

<u>Problem</u>	<u>Possible Cause</u>	<u>Corrective Action</u>
F. Discharge current immediately surges to a high value and blows DC fuse even though the current adjust knob is set low	Reversed polarity of battery connection	Ensure that polarity is respected on battery connection. If connector has been removed ensure that DC leads are not reversed.
	Defective power control module	With AC voltage and battery disconnected , open unit and remove heavy leads from terminals on black 1"x1-1/2 " (25 mmx37mm) power module. Check resistance between terminals with ohmmeter. If short circuit , call Lamar technical support at (360) 651-8869.

If trouble cannot be located contact Lamar Technologies technical support at (360) 651-8869.

## 7. SPECIFICATIONS

<b><u>AC Line Input:</u></b>		115 volts $\pm$ 10%, 50/60Hz, 3 amperes or 230 volts $\pm$ 10%, 50/60Hz, 1.5 amperes (selectable on rear of unit)
<b><u>DC Discharge Current:</u></b>	<b>Capacity</b>	0-50 amperes adjustable current
	<b>Accuracy</b>	$< \pm 2\%$ from discharge initiation to cut-off
<b><u>Timer</u></b>	<b>Setting</b>	Adjustable from 0 to 999.9 minutes
	<b>Accuracy</b>	$< \pm 0.1\%$
<b><u>Digital Meter Accuracy</u></b>	<b>Voltmeter</b>	$< \pm 0.2$ volts
	<b>Ammeter</b>	$< \pm 0.2$ amperes
<b><u>Cooling:</u></b>		Fan cooled
<b><u>Housing:</u></b>		Aluminum chassis
<b><u>Outer Dimensions:</u></b>	<b>Height</b>	14 in. (356 mm)
	<b>Depth</b>	15 in. (381 mm)
	<b>Width</b>	10 $\frac{1}{4}$ in. (260 mm)
<b><u>AC Line Cord:</u></b>		AWG 16 3 wire grounded 6 ft long with 115 volt 15 ampere plug. User required to change to 230 volt plug
<b><u>DC Discharge Cable:</u></b>		4 ft long, with Aircraft battery connector
<b><u>Weight:</u></b>		Net 33 lbs. Shipping 38 lbs.
<b><u>Fuses:</u></b>	<b>AC line fuse</b>	3A/250V, type MDA 1 $\frac{1}{4}$ x $\frac{1}{4}$
	<b>DC line fuse</b>	70AMAXI Fuse
<b><u>Modes:</u></b>		Analysis (automatic cut-off) and deep cycle (full discharge) with cutoff set to one volt.

---

## APPENDIX

---

### APPENDIX A - BATTERY OVERVIEW

#### CLASSES OF BATTERIES

Batteries can be divided into two major classes: primary and secondary. The primary batteries are not practically reusable once its useful energy has been discharged. The secondary battery is rechargeable. In the following only secondary batteries will be covered.

#### SECONDARY BATTERIES

Secondary batteries differ from primary batteries in that they may be recharged. Some of the materials in the cells of primary batteries are usually consumed in the process of changing chemical energy into electrical energy. In the secondary system, the materials are transferred from one electrode to the other as the cells discharge. The cells are restored to their original state of charge by forcing an electric current through the cells in a direction opposite to that of the discharge. These batteries are used in a multitude of applications ranging from megawatt sizes in submarines to milliwatt sizes in portable radios.

#### LEAD-ACID BATTERIES, VENTED OR SEALED (SLAB)

The lead-acid battery is a rechargeable system using acid electrolyte (sulfuric acid and water). Lead-acid batteries may be vented or sealed. The advantages of lead-acid batteries are that they have a low initial cost, require low maintenance, and their discard cost is low. The SLAB, on a per-weight basis, provides as much power as a nickel-cadmium battery. Lead-acid batteries shed active material from the positive plate, proportional to the number of charge/discharge cycles. This results in diminishing battery performance with age and loss of active material on the positive plates due to the washing action of the gas bubbles generated during charge. The open circuit voltage of a fully charged cell is about 2.1-2.2 volts. The discharge voltage is about 2.0 volts and varies with temperature, discharge rate, charge state, and age. The SLAB must be charged in a constant potential mode.

The lead-acid battery is the most widely used of the secondary battery types. Major applications include automobiles, aircraft, aircraft support equipment, and various industrial applications.

#### NICKEL-CADMIUM BATTERIES

The nickel-cadmium battery is a rechargeable system using alkaline electrolyte (a 31% aqueous solution potassium hydroxide). Nickel-cadmium batteries, which may be vented or sealed, have overcharge capability, high rate charge acceptance and nearly constant discharge voltage. The disadvantages are the high initial and maintenance costs as well as the cost to discard the battery at the end of life. The open circuit voltage of a fully charged cell is about 1.35 volts. The discharge voltage is about 1.2 to 1.1 volts and varies with temperature, discharge rate, charge state, and age.



Nickel-cadmium batteries are used in auxiliary power units, aircraft engine starting, space satellite power, missile electrical systems, and electrical propulsion

## DEFINITIONS

**AMPERE-HOURS.** The term "ampere-hours" is a unit of measure that refers to the electrical capacity of a battery. It is the product of the current in amperes multiplied by the period of time in hours during which the current is delivered. For example, a battery that discharges at 5.0 amperes for 4.0 hours has delivered  $5.0 \times 4.0$  or 20 ampere-hours. To convert ampere-minutes to ampere-hours, simply divide by 60. E.g.  $10 \text{ amperes} \times 40 \text{ minutes} = 400/60 \text{ ampere-hours} = 6.6 \text{ ampere-hours}$ .

**CUTOFF VOLTAGE.** The cutoff voltage is the voltage point on the discharge curve, for a specified discharge rate, at which the battery or cell is considered to be discharged for all practical purposes. To discharge beyond this point will yield little useful power due to the subsequent rapid voltage drop that occurs.

**CAPACITY RATE (C<sub>1</sub>-RATE).** The capacity rating of a lead-acid or nickel-cadmium battery is based on a one hour discharge rate with the battery initially at temperature 77.5°F (25°C) and a cutoff terminal voltage of 18.0 volts for a 24-volt battery or 9.0 volts for a 12-volt battery. For example, a 24-volt battery rated at 30.0 ampere-hours should deliver 30.0 amperes for a minimum of 1.0 hours before reaching the 18.0 volts cutoff voltage. This is a one-hour, C<sub>1</sub>-rate discharge.

### **1 YEAR WARRANTY**

LAMAR TECHNOLOGIES warrants its products to be free from defects in workmanship and material for a one year period from the date of shipment to the distributor, original equipment manufacturer (OEM), or original end user. If any product shall prove to be defective during the warranty period, LAMAR TECHNOLOGIES will repair or replace such part.

There are no warranties which extend beyond the description on the face hereof. This warranty is in lieu of all other warranties, express or implied. LAMAR TECHNOLOGIES excludes liability for incidental and consequential damages.

An action for breach of this warranty must be commenced within one year after the breach is or should have been discovered.

LAMAR TECHNOLOGIES specifically disclaims all other representations to the first user/ purchaser, and all other obligations or liabilities. No person is authorized to give any other warranties or to assume any liabilities on LAMAR TECHNOLOGIES' behalf.

## REPORT AND CERTIFICATION OF CALIBRATION

Manufacturer:

**Lamar Technologies LLC, 14900 40<sup>th</sup> Ave NE  
Marysville, WA 98271, (360) 651-8869 www.lamartech.com**

Date of Test \_\_\_\_\_ NSN: 6130-01-462-6337 & 6130-21-258-4430

S/N \_\_\_\_\_ P/N - Model **Beta D-50** MFR Date \_\_\_\_\_

Description:

Commercial Battery Discharge Tester

Notes on Calibration:

1. All instruments used for calibration are calibrated to standards traceable to National Institute of Standards and Technology.
2. Test instruments are calibrated annually by a certified test laboratory in compliance with the Calibration Systems Requirement of ISO/IEC 17025:2005, ANSI/NCSL Z540-1-1994, and a quality system registered to ISO 9001:2008

Report: Test Instruments Used:

Multimeter: S/N \_\_\_\_\_

Shunt: S/N \_\_\_\_\_

Results:

- All controls within specification.
- All digital/analog displays within calibration specification.
- Shipped condition all in tolerance, passed.

Tested by \_\_\_\_\_ Date \_\_\_\_\_

Calibration Recommended one year from date of first use:

# ***Power Products*** ***by*** ***Lamar*** ***Technologies LLC***

Designer and manufacturer of aircraft lead-acid and  
nickel-cadmium battery support equipment since 1980.  
Headquarters located in Marysville, Washington.

## **CONTACT INFORMATION:**

Lamar Technologies LLC

14900 40<sup>th</sup> Ave NE, Marysville, WA 98271

PH: 360-651-8869 E-Mail: [admin@lamartech.com](mailto:admin@lamartech.com)

[www.lamartech.com](http://www.lamartech.com)